

TEST REPORT

Product Name : Rechargeable Li-ion Battery (Home Energy Storage Battery (Lithium Battery Module))
Model Number : AT48-100H, VT-5139

Prepared for : V-TAC EXPORT LIMITED
Address : Room 301 Kam ON Building 176A ,Queen's Road Central HongKong

Prepared by : EMTEK (DONGGUAN) Co., Ltd.
Address : -1&2F., Building 2, Zone A, Zhongda Marine Biotechnology Research and Development Base, No. 9, Xincheng Avenue, Songshanhu High-technology Industrial Development Zone, Dongguan, Guangdong, China

Tel : +86-0769-22807078
Fax: +86-0769-22807079

Report Number : EDG2301030146E00101RM1
Date(s) of Tests : August 31, 2022 to October 08, 2022
Date of issue : January 04, 2023



TABLE OF CONTENT

Description	Page
1. DESCRIPTION OF STANDARDS AND RESULTS (EUT)	4
2. GENERAL INFORMATION	6
2.1. Description of Device (EUT)	6
2.2. Independent Operation Modes	6
2.3. Test Manner	6
2.4. Description of Support Device	6
2.5. Description of Test Facility	7
2.6. Measurement Uncertainty	7
3. MEASURING DEVICE AND TEST EQUIPMENT	8
3.1. For Radiated Emission Measurement (3m)	8
3.2. For Electrostatic Discharge Immunity	8
3.3. For Continuous RF Electromagnetic Field Disturbances Immunity	8
4. CONDUCTED EMISSIONS FROM THE AC MAINS POWER PORTS	9
4.1. Block Diagram of Test Setup	9
4.2. Limits	9
4.3. Test Procedure	9
4.4. Measuring Results	10
5. ASYMMETRIC MODE CONDUCTED EMISSIONS AT WIRED NETWORK PORTS	11
5.1. Block Diagram of Test Setup	11
5.2. Limits	11
5.3. Test Procedure	11
5.4. Measuring Results	12
6. RADIATED EMISSION MEASUREMENT (UP TO 1GHz)	13
6.1. Block Diagram of Test Setup	13
6.2. Radiated Limit	13
6.3. Test Procedure	13
6.4. Measuring Results	14
7. RADIATED EMISSION MEASUREMENT (ABOVE 1GHz)	17
7.1. Block Diagram of Test Setup	17
7.2. Radiated Limit	17
7.3. Test Procedure	18
7.4. Measuring Results	18
8. ELECTROSTATIC DISCHARGE	20
8.1. Test Specification	20
8.2. Block Diagram of Test Setup	20
8.3. Test Procedure	20
8.4. Test Results	21
9. CONTINUOUS RF ELECTROMAGNETIC FIELD DISTURBANCES	22
9.1. Test Specification	22
9.2. Block Diagram of Test Setup	22
9.3. Test procedure	22
9.4. Test results	23
10. PHOTOGRAPHS	24
10.1. Photos of Radiation Emission Measurement	24
10.2. Photo of Electrostatic Discharges	24
10.3. Photo of Continuous RF Electromagnetic Field Disturbances	25
APPENDIX (Photos of the EUT) (4 page)	

TEST REPORT DESCRIPTION

Applicant : V-TAC EXPORT LIMITED
Room 301 Kam ON Building 176A ,Queen's Road Central HongKong
Manufacturer : Dongguan Antai Electronic Technology Co.,Ltd
Building E,No.22,Yuhua Street,138 Industrial Area,Tangxia Town,Dongguan
City,China
Trade Mark : 
EUT : Rechargeable Li-ion Battery (Home Energy Storage Battery (Lithium Battery
Module))
Model Number : AT48-100H, VT-5139
Rating : DC 51.2V, 100Ah, 5120Wh

Measurement Procedure Used:

EN 55032:2015+A1:2020

EN 55035:2017+A11:2020

The device described above is tested by EMTEK (DONGGUAN) CO., LTD. and EMTEK(SHENZHEN) CO., LTD. to determine the maximum emission levels emanating from the device and the severe levels of the device can endure and its performance criterion. The measurement results are contained in this test report and EMTEK (DONGGUAN) CO., LTD. is assumed full of responsibility for the accuracy and completeness of these measurements. Also, this report shows that the EUT (Equipment Under Test) is technically compliant with the EN 55032 and EN 55035 requirements.

This report applies to above tested sample only and shall not be reproduced in part without written approval of EMTEK (DONGGUAN) CO., LTD.

Date of Test : August 31, 2022 to October 08, 2022

Prepared by : 
Galen Xiao /Editor

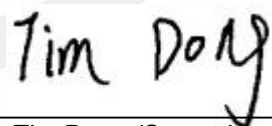
Reviewer : 
Tim Dong /Supervisor

Approve & Authorized Signer : 
Sam Lv /Manager



Modified Information

Version	Report No.	Revision Date	Summary
	EDG2210240123E00101R	October 25, 2022	Original Report
M1	EDG2301030146E00101RM1	January 04, 2023	Add the model number



1. DESCRIPTION OF STANDARDS AND RESULTS (EUT)

EMISSION				
Description of Test Item		Standard	Limits	Results
Conducted Emissions From the AC Mains Power Ports		EN 55032	Class B	N/A
Asymmetric mode conducted emissions	Wired network ports		Class B	N/A
	Optical fibre ports		Class B	N/A
	Broadcast receiver tuner ports		Class B	N/A
	Antenna ports		Class B	N/A
Conducted differential voltage emissions	TV broadcast receiver tuner ports		Class B	N/A
	RF modulator output ports		Class B	N/A
	FM broadcast receiver tuner ports		Class B	N/A
Radiated emissions at frequencies up to 1 GHz			Class B	Pass
Radiated emissions at frequencies above 1 GHz			Class B	N/A
Radiated emissions from FM receivers		Table A.6	N/A	
Outdoor units of home satellite receiving systems		Table A.7	N/A	
IMMUNITY				
Description of Test Item		Basic Standard	Performance Criteria	Results
Electrostatic Discharge	Enclosure ports	IEC 61000-4-2:2008	B	Pass
Continuous RF electromagnetic field disturbances	Enclosure ports	IEC 61000-4-3: 2020	A	Pass
Electrical fast transients/burst	AC mains power ports	IEC61000-4-4:2012	B	N/A
	Analogue/digital data ports		B	N/A
	DC network power ports		B	N/A
Surges	AC mains power ports	IEC 61000-4-5: 2014+AMD1:2017	B	N/A
	Analogue/digital data ports		B,C	N/A
	DC network power ports		B	N/A
Continuous induced RF disturbances	AC mains power ports	IEC 61000-4-6:2013/COR 1:2015	A	N/A
	Analogue/digital data ports		A	N/A
	DC network power ports		A	N/A
Power frequency magnetic field	Enclosure ports	IEC 61000-4-8:2009	A	N/A
Voltage dips and interruptions	AC mains power ports	IEC 61000-4-11: 2020	B,C	N/A
Broadband impulsive conducted disturbances	Analogue/digital data ports	\	N/A	N/A
Note: N/A is an abbreviation for Not Applicable. The test data is according to the test report EDG2208310286E00201R				

2. GENERAL INFORMATION

2.1. Description of Device (EUT)

EUT	: Rechargeable Li-ion Battery (Home Energy Storage Battery (Lithium Battery Module))
Model list	: AT48-100H, VT-5139 (Note: These models are the same, except for the model names and appearance; AT48-100H was selected for full test.)
Test Voltage	: DC 51.2V
Date of Received	: August 31, 2022
Date of Test	: August 31, 2022 to October 08, 2022

2.2. Independent Operation Modes

- A. Discharge
- B. Charging

2.3. Test Manner

Test Items	Test Voltage	Operation Modes	Worst case
Radiated emissions at frequencies up to 1 GHz	DC 51.2V	Mode A&B	Mode A
Electrostatic Discharge	DC 51.2V	Mode A&B	Mode A
Continuous RF electromagnetic field disturbances	DC 51.2V	Mode A&B	Mode A

2.4. Description of Support Device

DC Power Supply	: Manufacturer: ADMIRE POWER M/N: APD300-20L S/N: 930974
-----------------	--

2.5. Description of Test Facility

Site Description

EMC Lab. : Accredited by CNAS, 2020.08.27
 The certificate is valid until 2024.07.05
 The Laboratory has been assessed and proved to be in compliance with
 CNAS/CL01:2018
 The Certificate Registration Number is L3150

Accredited by FCC
 Designation Number: CN1300
 Test Firm Registration Number: 945551

Accredited by A2LA, April 05, 2021
 The Certificate Registration Number is 4321.02

Accredited by Industry Canada
 The Certificate Registration Number is CN0113

Name of Firm : EMTEK (DONGGUAN) Co., Ltd.
 Site Location : -1&2/F., Building 2, Zone A, Zhongda Marine Biotechnology Research and
 Development Base, N.9, Xincheng Avenue, Songshanhu High-technology
 Industrial Development Zone, Dongguan, Guangdong, China

2.6. Measurement Uncertainty

Test Item	Uncertainty
Conducted Emission Uncertainty	: 2.08dB(9k~150kHz Conduction 1#) 2.42dB(150k-30MHz Conduction 1#)
Radiated Emission Uncertainty (3m Chamber)	: 3.32dB (30M~1GHz Polarize: H) 3.34dB (30M~1GHz Polarize: V) 4.98dB (1~6GHz) 5.20dB (6~18GHz)
Uncertainty for Flicker test	: 0.07%
Uncertainty for Harmonic test	: 1.8%
Uncertainty for C/S Test	: 1.45(Using CDN Test)
Uncertainty for R/S Test	: 2.10dB(80MHz-200MHz) 1.76dB(200MHz-1000MHz)
Uncertainty for test site temperature and humidity	: 0.6°C 4%

3. MEASURING DEVICE AND TEST EQUIPMENT

3.1. For Radiated Emission Measurement (3m)

Item	Equipment	Manufacturer	Model No.	Serial No.	Last Cal.	Cal. Interval
1.	EMI Test Receiver	Rohde & Schwarz	ESCI	101415	2022/5/19	1Year
2.	Bilog Antenna	Schwarzbeck	VULB9163	141	2022/5/22	1Year
3.	Power Amplifier	HP	8447F	OPH64	2022/5/19	1Year
4.	Cable	N/A	CIL02	A0783566	2022/5/19	1Year
5.	Cable	N/A	RG 223/U	525178	2022/5/19	1Year
6.	Cable	N/A	RG 223/U	525179	2022/5/19	1Year

3.2. For Electrostatic Discharge Immunity

Item	Equipment	Manufacturer	Model No.	Serial No.	Last Cal.	Cal. Interval
1.	ESD Tester	TESEQ	NSG 437	409	2022/5/22	1Year

3.3. For Continuous RF Electromagnetic Field Disturbances Immunity

Item	Equipment	Manufacturer	Model No.	Serial No.	Last Cal.	Cal. Interval
1.	Power Amplifier	MILMEGA	AS0102-55	1018770	2022/5/14	1 Year
2.	50ohm Diode Power Sensor	BOONTON	51011EMC	34236	2022/5/16	1 Year
3.	RF Power Meter. Dual Channel	BOONTON	4232A	10539	2022/5/14	1 Year
4.	Log.-Per. Antenna	SCHWARZBECK	VULP 9118E	811	N/A	N/A
5.	Signal Generator	Agilent	N5181A	MY50145187	2022/5/14	1 Year
6.	50ohm Diode Power Sensor	BOONTON	51011EMC	36164	2022/5/14	1 Year
7.	Broad-Band Horn Antenna	SCHWARZBECK	STLP 9149	9149-227	N/A	N/A
8.	Field Strength Meter	DARE	RSS1006A	10I00037SNO 22	2022/5/15	1 Year
9.	Multi-function interface system	DARE	CTR1009B	12I00250SNO 72	N/A	N/A
10.	Automatic switch group	DARE	RSW1004A	N/A	N/A	N/A
11.	Power Amplifier	MILMEGA	AS1860-50	1059346	2022/5/14	1 Year
12.	Power Amplifier	MILMEGA	80RF1000-17 5	1059345	2022/5/14	1 Year
13.	Directional Coupler	MILMEGA	DC6180AM1	0340463	2022/5/14	1 Year
14.	Audio Analyzer	R&S	UPV	101473	2022/5/14	1 Year
15.	Audio Test System	AUDIO PRECISION	ATS-1	41100	2022/5/14	1 Year

4. CONDUCTED EMISSIONS FROM THE AC MAINS POWER PORTS

4.1. Block Diagram of Test Setup

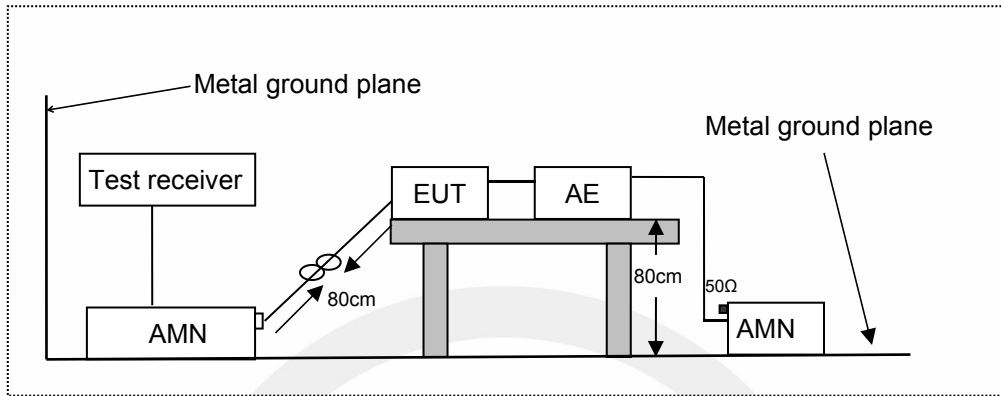

AMN: Artificial Mains Network
 AE: Associated equipment
 EUT: Equipment under test

4.2. Limits

EN 55032, Class B, Table A.10

Frequency range MHz	Coupling device (see Table A.10)	Detector type / bandwidth	Class B limits dB(μV)
0.15 to 0.5	AMN	Quasi Peak / 9 kHz	66 to 56
0.5 to 5			56
5 to 30			60
0.15 to 0.5	AMN	Average / 9 kHz	56 to 46
0.5 to 5			46
5 to 30			50

4.3. Test Procedure

The EUT was placed on a desk 0.8 m height from the metal ground plane and 0.4 m from the conducting wall of the shielding room and it was kept at least 0.8 m from any other grounded conducting surface. The size of the table will nominally be 1.5 m x1.0 m.

The rear of the arrangement shall be flush with the back of the supporting tabletop unless that would not be possible or typical of normal use.

All units of equipment forming the system under test (includes the EUT as well as connected peripherals and associated equipment or devices) shall be arranged such that a nominal 0.1 m separation is achieved between the neighboring units.

Connect EUT to the power mains through a artificial mains network (AMN). Where the mains cable supplied by the manufacturer is longer than 1 m, the excess should be folded at the centre into a bundle

no longer than 0.4 m, so that its length is shortened to 1 m.

All the support units are connecting to the other AMN.

The AMN provides 50 ohm coupling impedance for the measuring instrument.

The CISPR states that the AMN with 50 ohm and 50 microhenry should be used.

Both sides of AC line were checked for maximum conducted interference.

The frequency range from 150 kHz to 30 MHz was sweep.

Set the test-receiver system to quasi peak detect function and average detect function, and to measure the conducted emissions values.

Test results were obtained from the following equation:

Emission Level (dB μ V) = AMN Factor (dB) + Cable Loss (dB) + Reading (dB μ V)

Margin (dB) = Emission Level (dB μ V) - Limit (dB μ V)

4.4. Measuring Results

N/A.

No AC power port.

5. ASYMMETRIC MODE CONDUCTED EMISSIONS AT WIRED NETWORK PORTS

5.1. Block Diagram of Test Setup

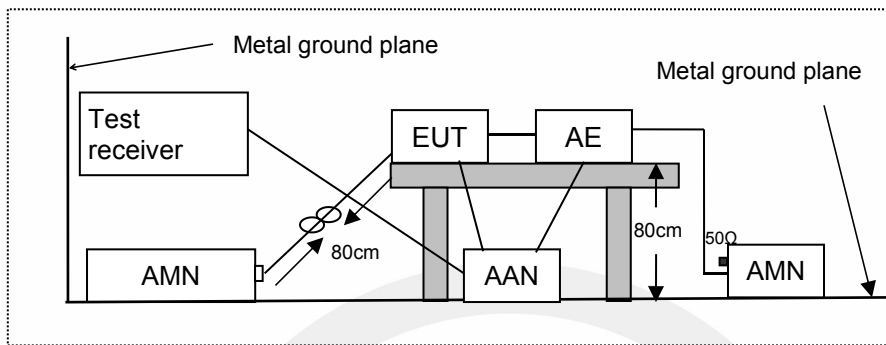

AMN: Artificial mains network
 AE: Associated equipment
 EUT: Equipment under test
 AAN: Asymmetric artificial network

5.2. Limits

EN 55032, Class B, Table A.12

Frequency range (MHz)	Coupling device (see Table A.12)	Detector type / bandwidth	Class B voltage limits dB(μV)	Class B current limits dB(μA)
0.15 to 0.5	AAN	Quasi Peak / 9 kHz	84 to 74	N/A
0.5 to 30			74	
0.15 to 0.5	AAN	Average / 9 kHz	74 to 64	
0.5 to 30			64	
0.15 to 0.5	CVP and current probe	Quasi Peak / 9 kHz	84 to 74	40 to 30
0.5 to 30			74	30
0.15 to 0.5	CVP and current probe	Average / 9 kHz	74 to 64	30 to 20
0.5 to 30			64	20
0.15 to 0.5	Current Probe	Quasi Peak / 9 kHz	N/A	40 to 30
0.5 to 30				30
0.15 to 0.5	Current Probe	Average / 9 kHz		30 to 20
0.5 to 30				20

5.3. Test Procedure

The EUT is put on the plane 0.8m high above the ground by insulating support and connected to the AC mains through artificial mains network(AMN) or connected to the wired network port through an asymmetric artificial network(ANN). AMN provided a 50ohm coupling impedance for the tested equipment AC mains port, ANN provided a common mode (asymmetric mode) impedance of 150 Ω to

the wired network port under test. Both sides of AC line and the wired network line are investigated to find out the maximum conducted emission according to the EN 55032 regulations during conducted emission measurement.

The bandwidth of the receiver is set at 9kHz in 150kHz~30MHz. The frequency range from 150kHz to 30MHz is investigated.

Test results were obtained from the following equation:

Emission Level (dB μ V) = ANN Factor (dB) + Cable Loss (dB) + Reading (dB μ V)

Margin (dB) = Emission Level (dB μ V) - Limit (dB μ V)

5.4. Measuring Results

N/A.

No wired network ports.



6. RADIATED EMISSION MEASUREMENT (UP TO 1GHz)

6.1. Block Diagram of Test Setup

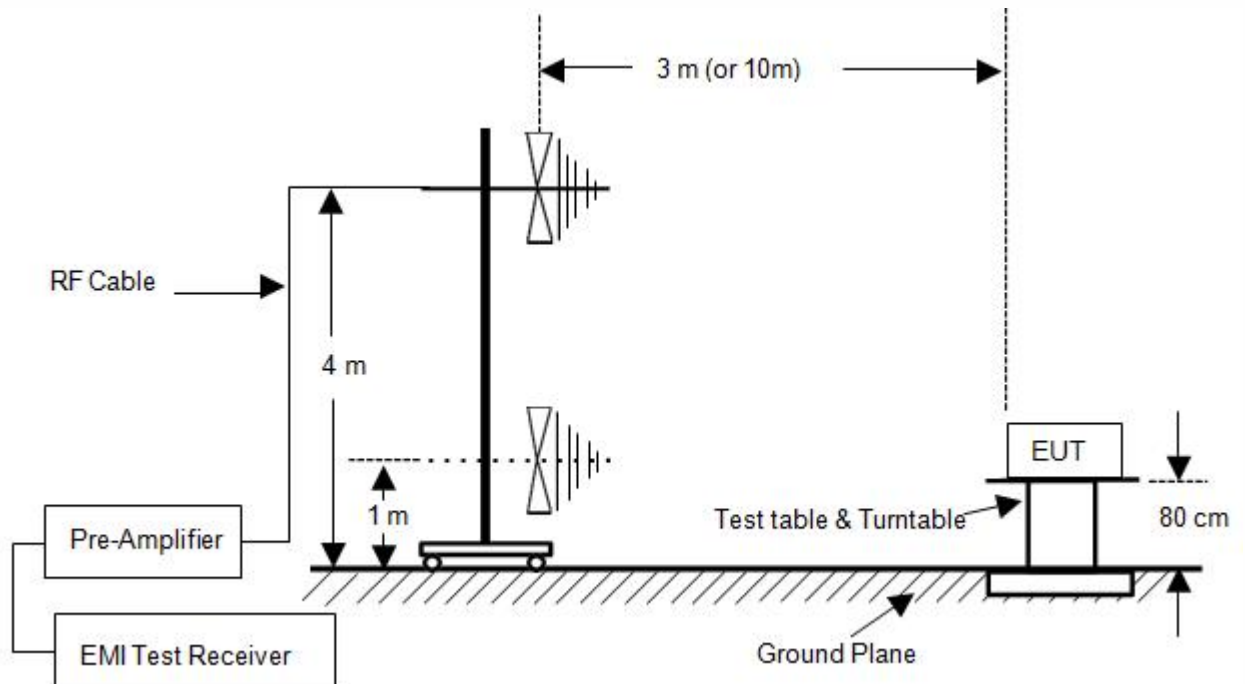

6.2. Radiated Limit

EN 55032, Class B, Table A.4

Frequency range MHz	Measurement			Class B limits dB(μ V/m)
	Facility	Distance (m)	Detector type / bandwidth	
30 to 230	OATS/SAC	10	Quasi Peak / 120 kHz	30
230 to 1 000				37
30 to 230	OATS/SAC	3		40
230 to 1 000				47

6.3. Test Procedure

The EUT was placed on a non-conductive table whose total height equaled 80cm. All units of equipment forming the system under test (includes the EUT as well as connected peripherals and associated equipment or devices) shall be arranged such that a nominal 0.1 m separation is achieved between the neighboring units. Where the mains cable supplied by the manufacturer is longer than 1 m, the excess should be folded at the centre into a bundle no longer than 0.4 m, so that its length is shortened to 1 m.

The EUT was set 3 meters (or 10 meters) away from the receiving antenna that was mounted on a non-conductive mast. The antenna can move up and down between 1 to 4 meters to find out the

maximum emission level.

The turntable can rotate 360 degree to determine the position of the maximum emission level.

The initial testing identified the frequency that has the highest disturbance relative to the limit while operating the EUT in typical modes of operation and cable positions in a test setup representative of typical system configuration.

The identification of the frequency of highest emission with respect to the limit was found by investigating emissions at a number of significant frequencies. The probable frequency of maximum emission had been found and that the associated cable and EUT configuration and mode of operation had been identified.

The bandwidth of the Receiver is set at 120 kHz.

Test results were obtained from the following equation:

Emission level (dB μ V/m) = Antenna Factor - Amp Factor + Cable Loss + Reading

Margin (dB) = Emission Level (dB μ V/m) - Limit (dB μ V/m)

6.4. Measuring Results

PASS.

The worst data are attached the following pages.



Site Chamber #1 Polarization: **Horizontal** Temperature: 25.9
 Limit: EN 55032_Class B 3m(RE) Power: DC 51.2V Humidity: 57 %

Mode: Discharge
 Note:

No.	Mk.	Freq.	Reading Level	Correct Factor	Measurement	Limit	Over	Antenna Height	Table Degree	
		MHz	dBuV	dB	dBuV/m	dBuV/m	dB	cm	degree	Comment
1	!	99.1797	55.77	-19.03	36.74	40.00	-3.26			QP
2	!	128.1130	55.80	-19.33	36.47	40.00	-3.53			QP
3	*	165.4866	58.10	-18.41	39.69	40.00	-0.31			QP
4	!	200.6881	52.10	-15.96	36.14	40.00	-3.86			QP
5	!	227.6906	53.09	-15.11	37.98	40.00	-2.02			QP
6		280.0237	45.35	-13.58	31.77	47.00	-15.23			QP

*:Maximum data x:Over limit !:over margin

Operator: Ccyf



Site Chamber #1 Polarization: **Vertical** Temperature: 25.9
 Limit: EN 55032_Class B 3m(RE) Power: DC 51.2V Humidity: 57 %

Mode: Discharge
 Note:

No.	Mk.	Freq.	Reading Level	Correct Factor	Measurement	Limit	Over	Antenna Height	Table Degree	
		MHz	dBuV	dB	dBuV/m	dBuV/m	dB	cm	degree	Comment
1	*	106.0126	54.16	-18.30	35.86	40.00	-4.14			QP
2	!	129.0145	55.06	-19.38	35.68	40.00	-4.32			QP
3	!	160.3456	54.00	-18.55	35.45	40.00	-4.55			QP
4		211.5263	47.93	-15.61	32.32	40.00	-7.68			QP
5		233.3486	43.84	-14.92	28.92	47.00	-18.08			QP
6		287.9904	42.32	-13.36	28.96	47.00	-18.04			QP

*:Maximum data x:Over limit !:over margin

Operator: Ccyf

7. RADIATED EMISSION MEASUREMENT (ABOVE 1GHz)

7.1. Block Diagram of Test Setup

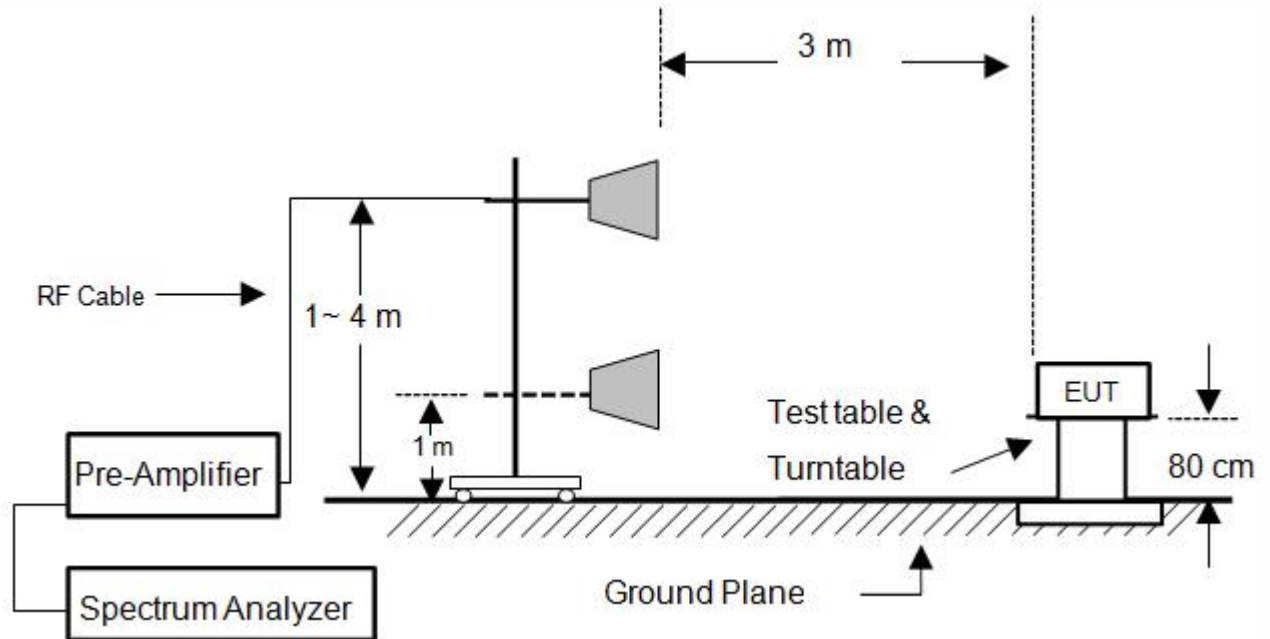

7.2. Radiated Limit

EN 55032, Class B, Table A.5

Frequency range (MHz)	Measurement			Class B limits dB(μ V/m)
	Facility	Distance (m)	Detector type/ bandwidth	
1000 to 3000	FSOATS	3	Average / 1 MHz	50
3000 to 6000				54
1000 to 3000			Peak /1 MHz	70
3000 to 6000				74

Note: The highest internal source of an EUT is defined as the highest frequency generated or used within the EUT or on which the EUT operates or tunes. If the highest frequency of the internal sources of the EUT is less than 108 MHz, the measurement shall only be made up to 1 GHz. If the highest frequency of the internal sources of the EUT is between 108 MHz and 500 MHz the measurement shall only be made up to 2 GHz. If the highest frequency of the internal sources of the EUT is between 500 MHz and 1 GHz, the measurement shall only be made up to 5 GHz. If the highest frequency of the internal sources of the EUT is above 1 GHz, the measurement shall be made up to 5 times the highest frequency or 6 GHz, whichever is less.

7.3. Test Procedure

The EUT was placed on a non-conductive table whose total height equaled 80cm. All units of equipment forming the system under test (includes the EUT as well as connected peripherals and associated equipment or devices) shall be arranged such that a nominal 0.1 m separation is achieved between the neighboring units. Where the mains cable supplied by the manufacturer is longer than 1 m, the excess should be folded at the centre into a bundle no longer than 0.4 m, so that its length is shortened to 1 m.

The EUT was set 3 meters away from the receiving antenna that was mounted on a non-conductive mast. The antenna can move up and down between 1 to 4 meters to find out the maximum emission level.

The turntable can rotate 360 degree to determine the position of the maximum emission level.

The initial testing identified the frequency that has the highest disturbance relative to the limit while operating the EUT in typical modes of operation and cable positions in a test setup representative of typical system configuration.

The identification of the frequency of highest emission with respect to the limit was found by investigating emissions at a number of significant frequencies. The probable frequency of maximum emission had been found and that the associated cable and EUT configuration and mode of operation had been identified.

The frequency range above 1GHz the measuring instrument use RBW=1 MHz and VBW=3 MHz.

Test results were obtained from the following equation:

Emission level (dB μ V/m) = Antenna Factor -Amp Factor +Cable Loss + Reading

Margin (dB) = Emission Level (dB μ V/m) - Limit (dB μ V/m)

7.4. Measuring Results

N/A.

The highest frequency of the internal sources of the EUT is less than 108 MHz.

Immunity General performance criteria Description

General performance criteria are defined in EN 55035 clause 8.2, 8.3 and 8.4. These criteria shall be used during the testing of primary functions where no relevant annex is applicable.

When assessing the impact of a disturbance on a function, the assessment should take into consideration the function's performance prior to the application of the disturbance and only identify as failures those changes in performance that are a result of the disturbance.

EN 55035:

Performance criterion A

The equipment shall continue to operate as intended without operator intervention. No degradation of performance, loss of function or change of operating state is allowed below a performance level specified by the manufacturer when the equipment is used as intended. The performance level may be replaced by a permissible loss of performance. If the minimum performance level or the permissible performance loss is not specified by the manufacturer, then either of these may be derived from the product description and documentation, and by what the user may reasonably expect from the equipment if used as intended.

Performance criterion B

During the application of the disturbance, degradation of performance is allowed. However, no unintended change of actual operating state or stored data is allowed to persist after the test.

After the test, the equipment shall continue to operate as intended without operator intervention; no degradation of performance or loss of function is allowed, below a performance level specified by the manufacturer, when the equipment is used as intended. The performance level may be replaced by a permissible loss of performance.

If the minimum performance level (or the permissible performance loss), or recovery time, is not specified by the manufacturer, then either of these may be derived from the product description and documentation, and by what the user may reasonably expect from the equipment if used as intended.

Performance criterion C

Loss of function is allowed, provided the function is self-recoverable, or can be restored by the operation of the controls by the user in accordance with the manufacturer's instructions. A reboot or re-start operation is allowed. Information stored in non-volatile memory, or protected by a battery backup, shall not be lost.

8. ELECTROSTATIC DISCHARGE

8.1. Test Specification

Test standard	: EN 55035
Basic standard	: IEC 61000-4-2
Performance criterion	: B
Test level	: ±8.0kV (Air discharge) ±4.0kV (Contact discharge)

8.2. Block Diagram of Test Setup

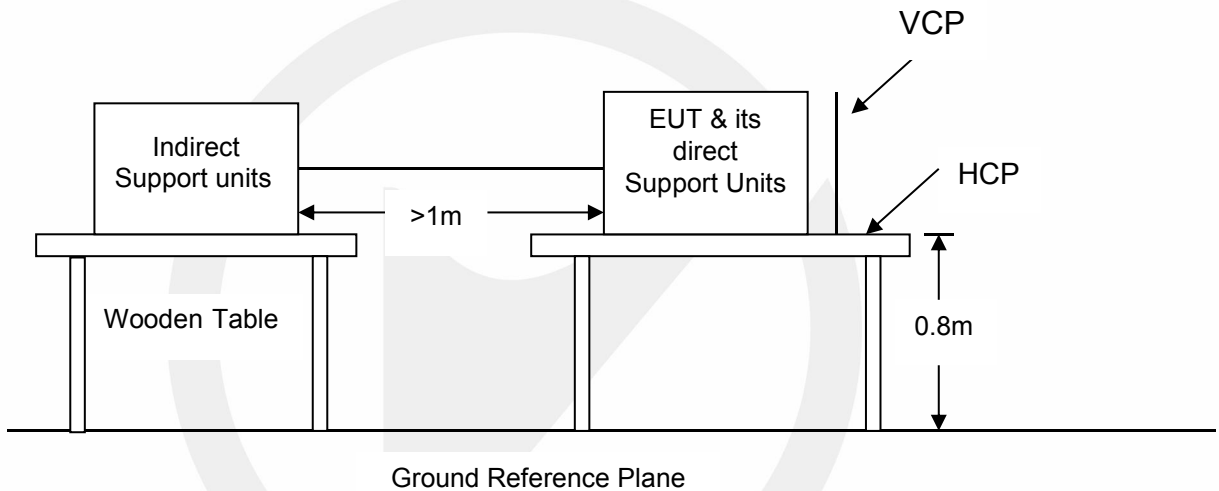

8.3. Test Procedure

- In the case of air discharge testing, the climatic conditions shall be within the following ranges:
 - ambient temperature: 15°C to 35°C;
 - relative humidity : 30% to 60%;
 - atmospheric pressure : 86 kPa (860 mbar) to 106 kPa (1060 mbar)
- Test programs and software shall be chosen so as to exercise all normal modes of operation of the EUT. The use of special exercising software is encouraged, but permitted only where it can be shown that the EUT is being comprehensively exercised.
- In the case of contact discharges, the tip of the discharge electrode shall touch the EUT before the discharge switch is operated.
- In the case of painted surface covering a conducting substrate, the following procedure shall be adopted :
 - If the coating is not declared to be an insulating coating by the equipment manufacturer, then the pointed tip of the generator shall penetrate the coating so as to make contact with the conducting substrate.
 - Coating declared as insulating by the manufacturer shall only be submitted to the air discharge.
 - The contact discharge test shall not be applied to such surfaces.
- In the case of air discharges, the round discharge tip of the discharge electrode shall be approached as fast as possible (without causing mechanical damage) to touch the EUT. After each discharge, the ESD generator (discharge electrode) shall be removed from the EUT. The generator is then retriggered for a new single discharge. This procedure shall be repeated until the discharges are completed. In the case of an air discharge test, the discharge switch, which is used for contact discharge, shall be closed.

- f. The test voltage shall be increased from the minimum to the selected test severity level, in order to determine any threshold of failure. The final test level should not exceed the product specification value in order to avoid damage to the equipment.
- g. The test shall be performed with both air discharge and contact discharge. The test shall be performed with single discharges. On each pre-selected point at least 10 single discharges (in the most sensitive polarity) shall be applied. For the time interval between successive single discharges an initial value of 1 s is recommended. Longer intervals may be necessary to determine whether a system failure has occurred.
- h. Ensure that the applied charge on the EUT has been dis-charged before next ESD pulse.

8.4. Test Results

PASS

Temperature : 25.8 °C
 Humidity : 57.4%
 Atmospheric Pressure : 101kpa
 Test Engineer : Ccyf
 Test Date : 2022-10-08

Air Discharge:

Test Voltage	Location	Actual criterion	Required performance criterion	Result (Pass/Fail)
±2; 4; 8 kV	Gap	A	B	Pass
±2; 4; 8 kV	Non-Metal part	A	B	Pass

Contact Discharge

Test Voltage	Location	Actual criterion	Required performance criterion	Result (Pass/Fail)
±2; 4kV	Metal part	A	B	Pass

Indirect Discharge

Test Voltage	Location	Actual criterion	Required performance criterion	Result (Pass/Fail)
±2; 4 kV	HCP	A	B	Pass
±2; 4kV	VCP	A	B	Pass

9. CONTINUOUS RF ELECTROMAGNETIC FIELD DISTURBANCES

9.1. Test Specification

Test standard	: EN 55035	
Basic standard	: IEC 61000-4-3	
Performance criterion	: A	
Frequency range &	: <input checked="" type="checkbox"/> 80M-1000MHz	3V/m
Test level	: <input checked="" type="checkbox"/> Spot frequency	3V/m
	: <input type="checkbox"/> Additional spot frequency	3V/m
Modulation	: AM, 80%, 1kHz sine-wave	

9.2. Block Diagram of Test Setup

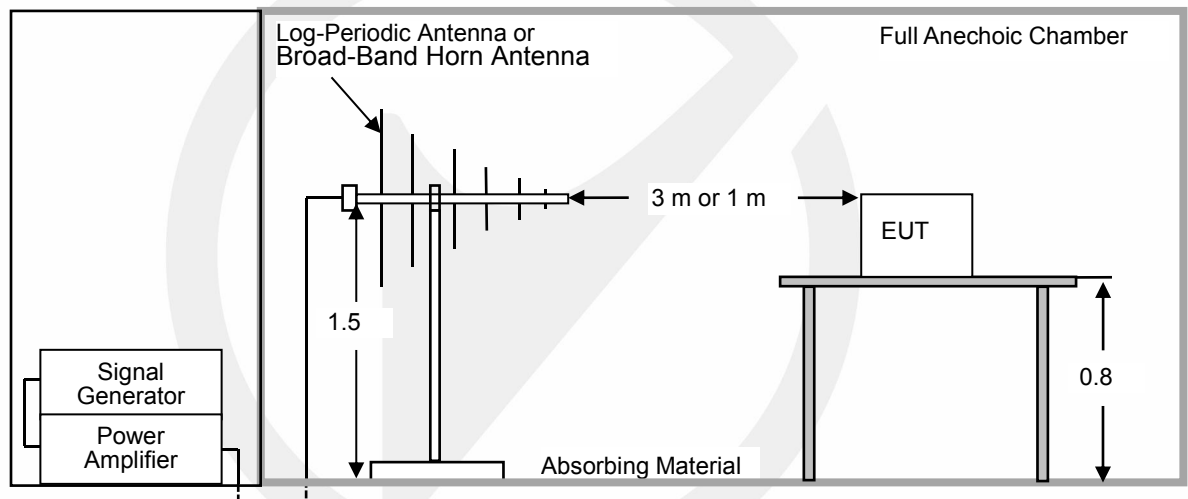

9.3. Test procedure

The procedure defined in this part requires the generation of electromagnetic fields within which the test sample is placed and its operation observed. To generate fields that are useful for simulation of actual (field) conditions may require significant antenna drive power and the resultant high field strength levels. To comply with local regulations and to prevent biological hazards to the testing personnel, it is recommended that these tests be carried out in a shielded enclosure or semi-anechoic chamber.

- a. The antenna which is enabling the complete frequency range of 80-1000 MHz is placed 3m (or 1m) away from the equipment. The required field strength is determined by placing the field strength meter(s) on top of or directly alongside the equipment under test and monitoring the field strength meter via a remote field strength indicator outside the enclosure while adjusting the continuous-wave to the antenna.
- b. The test is performed with the antenna facing the front and back sides of the EUT with. Both vertical and horizontal polarizations from antenna are tested.

9.4. Test results

These test result outsourced to EMTEK(SHENZHEN) CO., LTD.

PASS

Temperature : 26.2 °C
 Humidity : 56.8%
 Atmospheric Pressure : 101kpa
 Test Engineer : Ccyf
 Test Date : 2022-10-08

80M-1000MHz:

Freq. Range (MHz)	Field	Modulation	Polarity	Position (°)	Actual criterion	Required performance criterion	Result
80-1000	3V/m	AM, 80%	H / V	0, 90,180, 270	A	A	Pass

Spot frequency:

Freq (MHz)	Field	Modulation	Polarity	Position (°)	Actual criterion	Required performance criterion	Result
1800, 2600, 3500, 5000	3V/m	AM, 80%	H / V	0, 90,180, 270	A	A	Pass

10. PHOTOGRAPHS

10.1.Photos of Radiation Emission Measurement



10.2.Photo of Electrostatic Discharges



10.3.Photo of Continuous RF Electromagnetic Field Disturbances

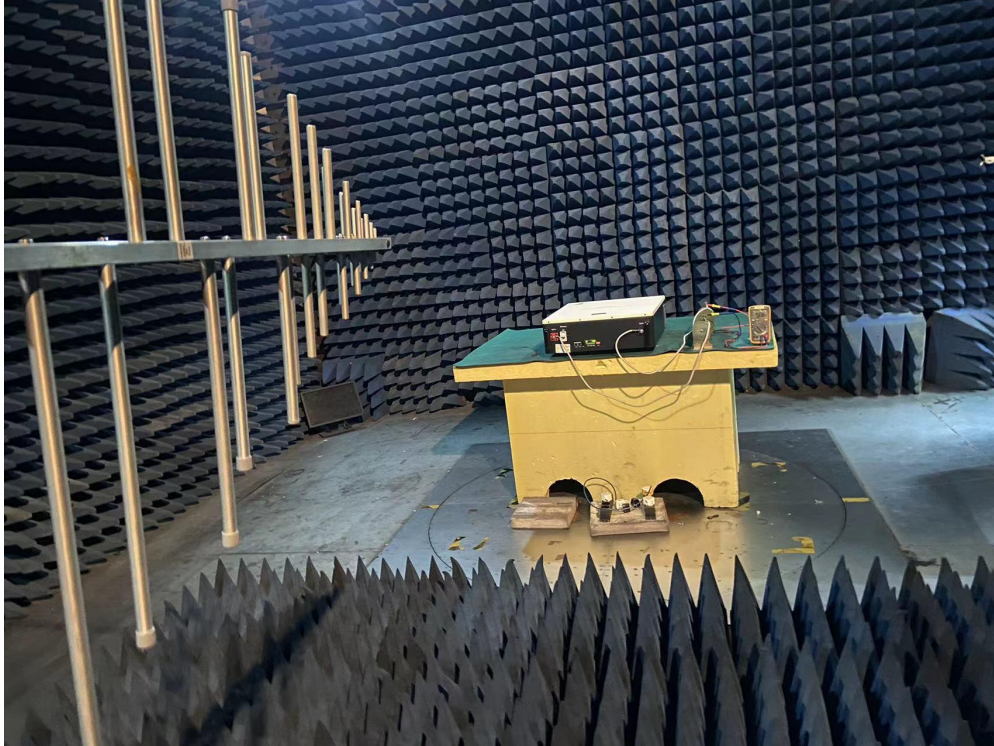



**APPENDIX
(PHOTOS OF EUT)**









---The end---

声明

Statement

1. 本报告无授权批准人签字及“检验报告专用章”无效；
This report will be void without authorized signature or special seal for testing report.
2. 未经许可本报告不得部分复制；
This report shall not be copied partly without authorization.
3. 本报告的检测结果仅对送测样品有效，委托方对样品的代表性和资料的真实性负责；
The test results or observations are applicable only to tested sample. Client shall be responsible for representativeness of the sample and authenticity of the material.
4. 本检测报告中检测项目标注有特殊符号则该项目不在资质认定范围内，仅作为客户委托、科研、教学或内部质量控制等目的使用；
The observations or tests with special mark fall outside the scope of accreditation, and are only used for purpose of commission, research, training, internal quality control etc.
5. 本检测报告以实测值进行符合性判定，未考虑不确定度所带来的风险，本实验室不承担相关责任，特别约定、标准或规范中有明确规定的除外；
The test results or observations are provided in accordance with measured value, without taking risks caused by uncertainty into account. Without explicit stipulation in special agreements, standards or regulations, EMTEK shall not assume any responsibility.
6. 对本检测报告若有异议，请于收到报告之日起 20 日内提出；
Objections shall be raised within 20 days from the date receiving the report.