Aluminum Profile Triangle Bracket

M1B-W1150

Installation Instructions



Contents

Section 1-Safe Guard Instruction	3
Section 2-Introduction of Triangle Bracket Mounting System	4
Package	4
Parts List	5
Effect drawing	6
Section 3-Installation procedures	7
Pre-installation chapter	7
Step 1- Install the beam and bottom beam	7
Step 2- Install the telescopic rod	8
Step 3- Install solar panels	9
Step 4- Optional installation	10
Section 4-Final process of assembly	11
Check after installation	13
Daily maintenance	13

Section 1-Safe Guard Instruction



Warning

- Mounting bracket system should be far away from combustible. The installer need to prevent fire nearing flammable or combustible goods.
- When the fire happened, the first thing is to make sure the safety of aluminum pieces if permit. The Subsequent should be installed after being checked by professional people.
- The parts of the system has been treated on the surface, So it needs to avoid damage during installation and transportation.
- Make sure the right installing sequence, position and procedure during installation, or the damage maybe happened.
- Components connection should be always kept in good condition, avoiding sliding and damaging.
- In case of personal injuries, The installer must wear safety precautions before installing.
- In case of problems and accident, Assembling work must follow the instruction manual.
- Please don't install or operate if the system is destroyed or is short of components.
- During installing and debugging, installers should pay attention to their own security and the falling objects to avoid being injured or bruised.
- Before installation, the ice, snow and dew on the surface of the components should be cleared away on condition that their coatings are not destroyed.
- The rubbing surface of bolts should be cleaned before installation. No dirt such as droplets, mud or greasy dirt.







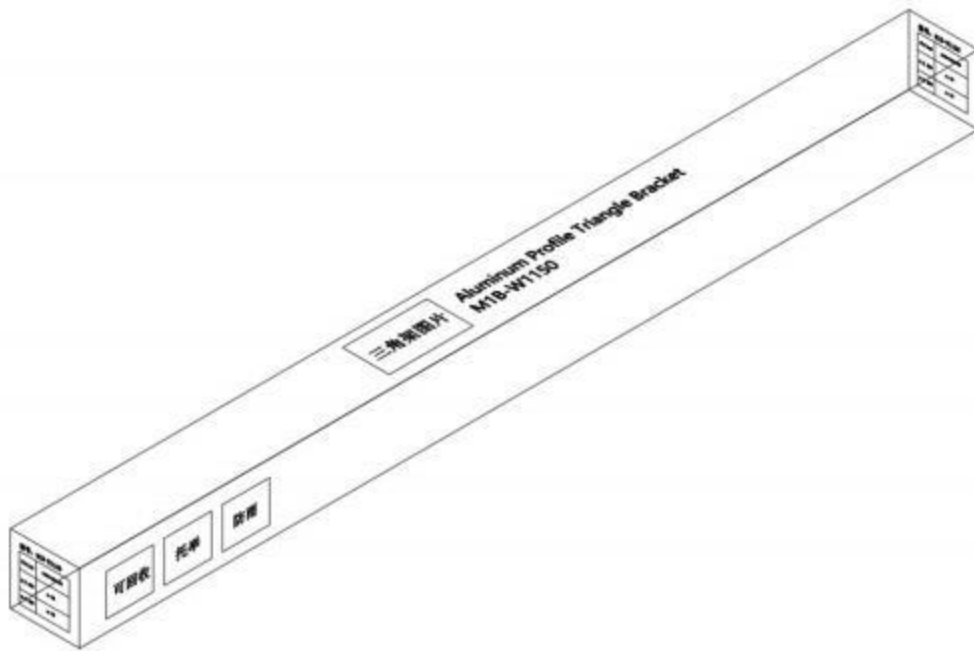

Section 2-Introduction of Triangle Bracket Mounting System

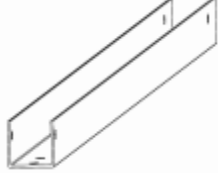
Product	Aluminum Profile Triangle Bracket (M1B-W1150)
Application	Ground/ Roof/ Guardrail
Tilt Angle	10°- 15°
Material	AL6005-T5/SUS304
Panel Layout	Landscape
Max PV width	1150mm
Design Standard	AS/NZS 1170, DIN 1055, JIS C8955: 2017, International Building Code IBC 200
Warranty	10 year

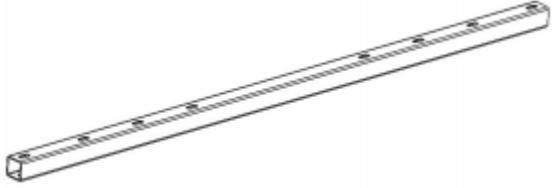
Package



Parts List

<p>Beam 1250mm x 2</p>	<p>bottom beam 1250mm x 2</p>
	
<p>telescopic rod 210mm * 2 x 2</p>	<p>Side Clamp 40mm x 4</p>
	
<p>cross arm and bolt set x 1 1069mm (Optional)</p>	<p>Bolt Set M8 * 95 x 6</p>
	
<p>Bolt Set M8 * 55 x 6</p>	<p>St 6 3 * 25 x 2</p>
	
<p>SUS304 plate and bolt set 300mm x 2(Optional)</p>	<p>Allen key 6mm x 1</p>
	
<p>External hexagon wrench 13mm x 1</p>	<p>Wire rope x 2</p>

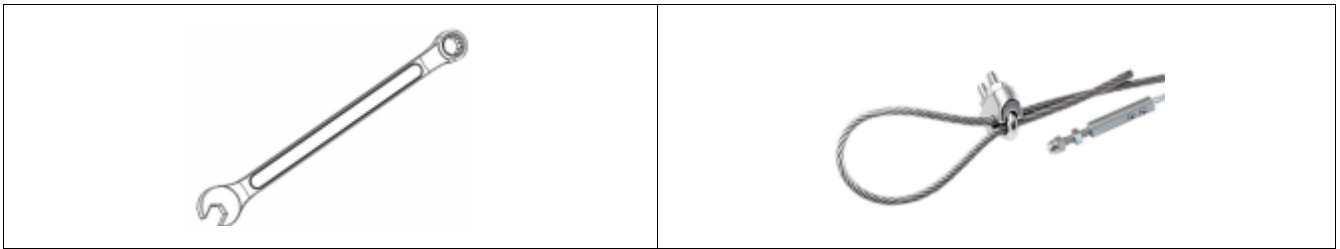

***Some accessories that are pre-installed on the product are not otherwise listed in the parts list**



Effect drawing

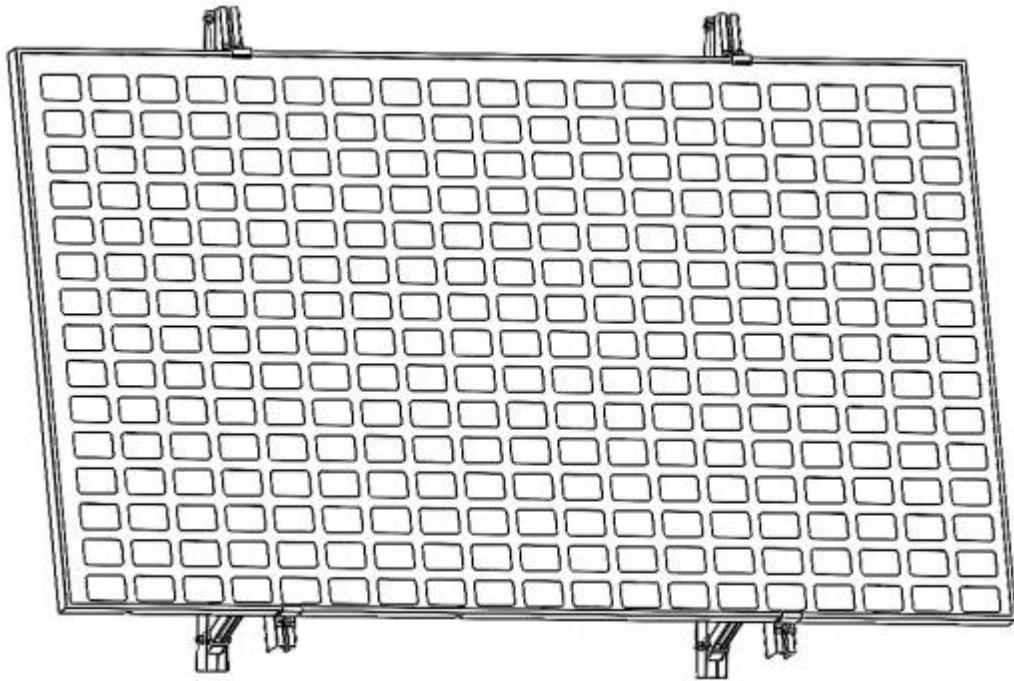

Front View

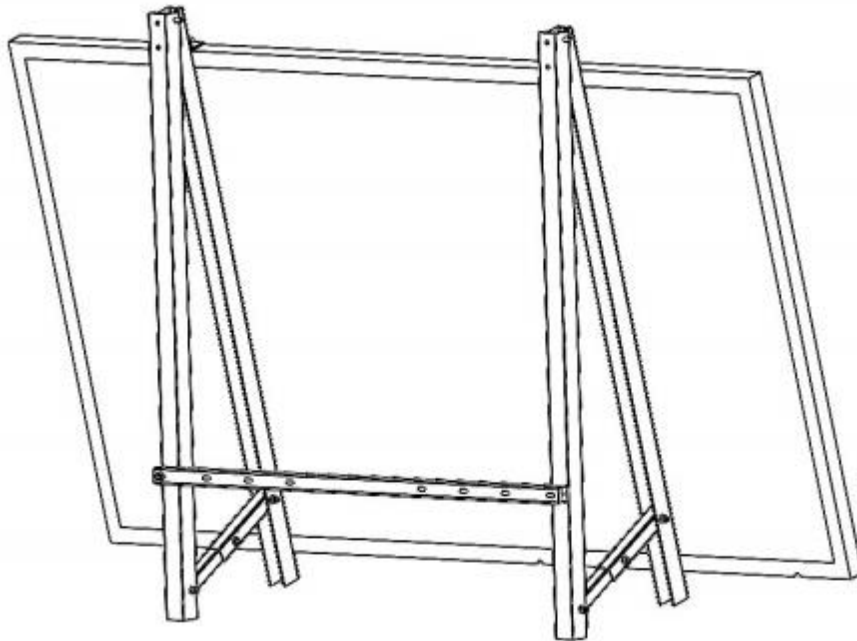

Rear view

Section 3-Installation procedures

Pre-installation chapter

◆ Read the installation instruction



Please read the instructions carefully before installing, to make sure the installation and debugging are conducted in order.



Warning: please install according to our

◆ All bolt groups are installed as a the other side.

bolt

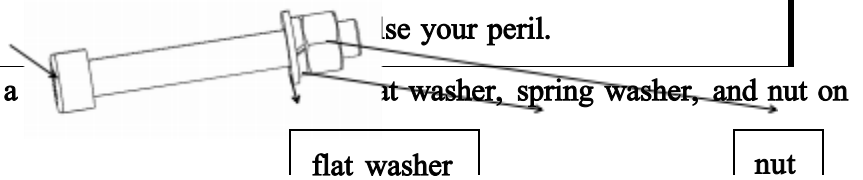

Use your peril.

flat washer, spring washer, and nut on

flat washer

nut

spring washer

Step 1 - Install the beam and bottom beam

Open pre-assembled beams and bottom beams, A set of M8 * 60 bolts are used at the connection between the be

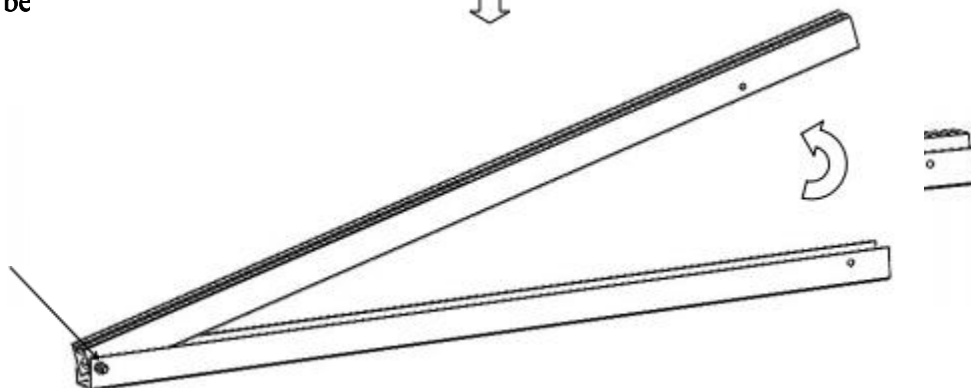

M8*60 bolt set

Step 2- Install the telescopic rod

- a. Before installing the telescopic rod on the beam, check whether the support block on the telescopic rod is installed.

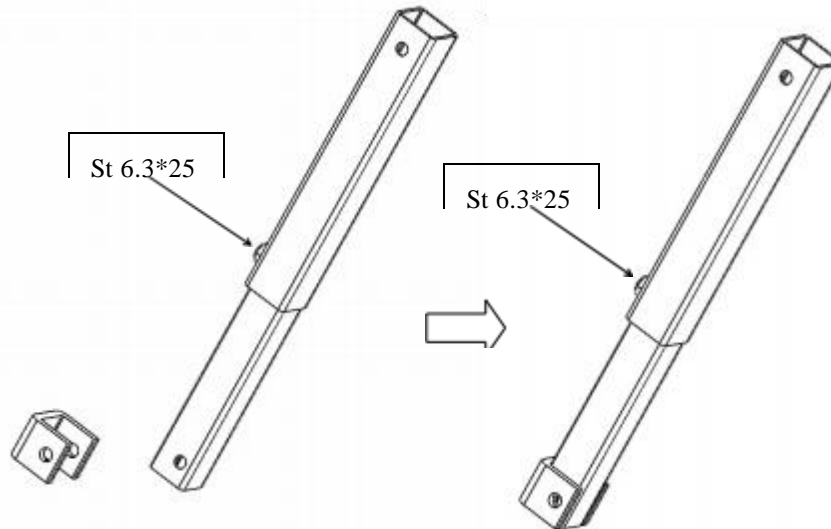

- b. Install the telescopic rod on the bottom beam through the M8*60 bolt group, and install the telescopic rod on the beam through the M8*55 bolt group

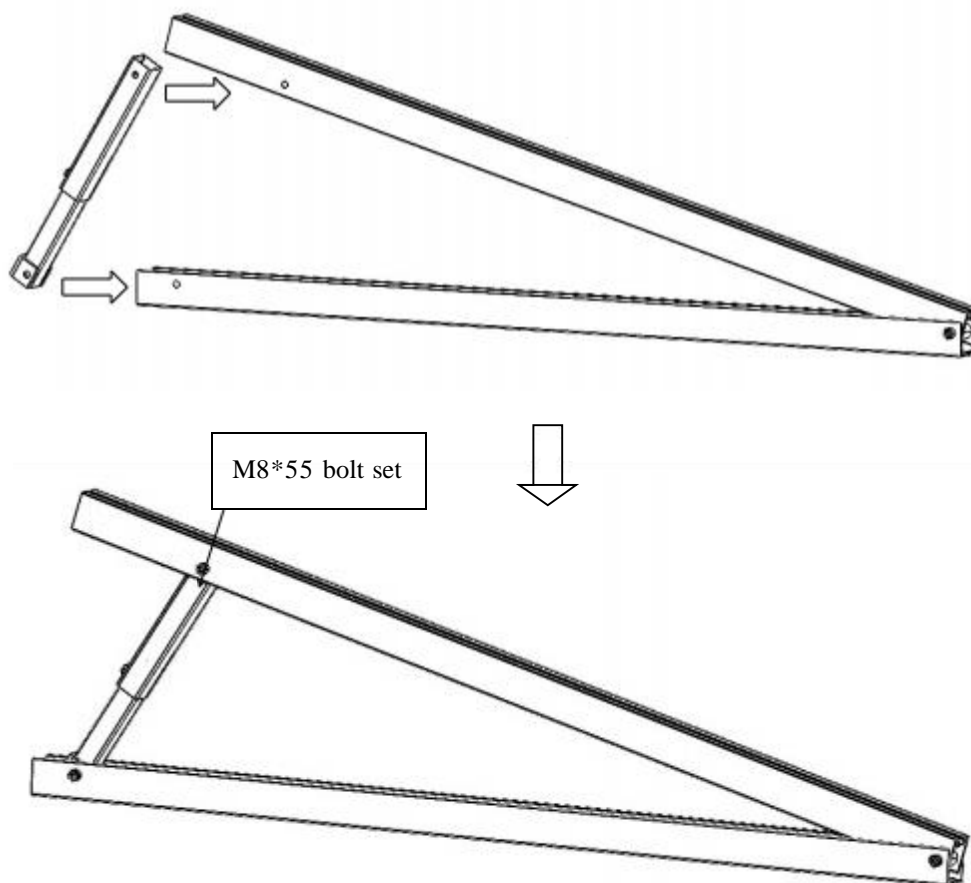

c. Do the same steps for the other set of tripods

Step 3- Install solar panels

- a. Mount the Side Clamp to the beam by turning the T-bolt

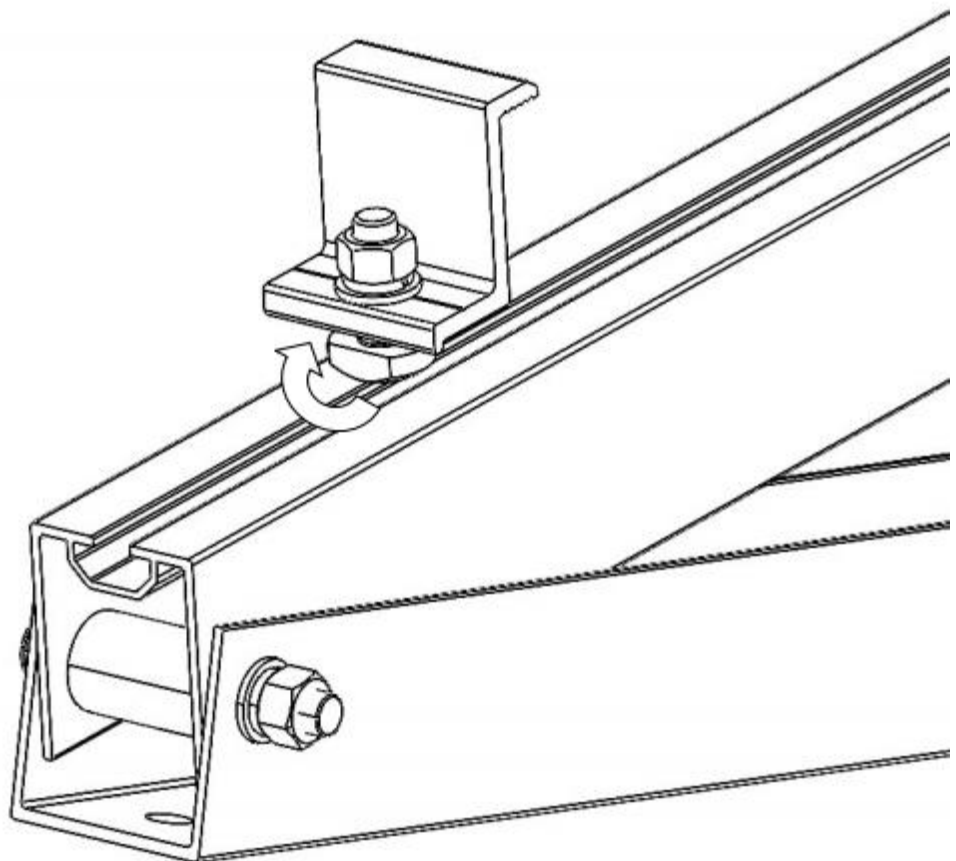

- b. Pre-install Side Clamp at the bottom of the tripod to prevent the module from slipping

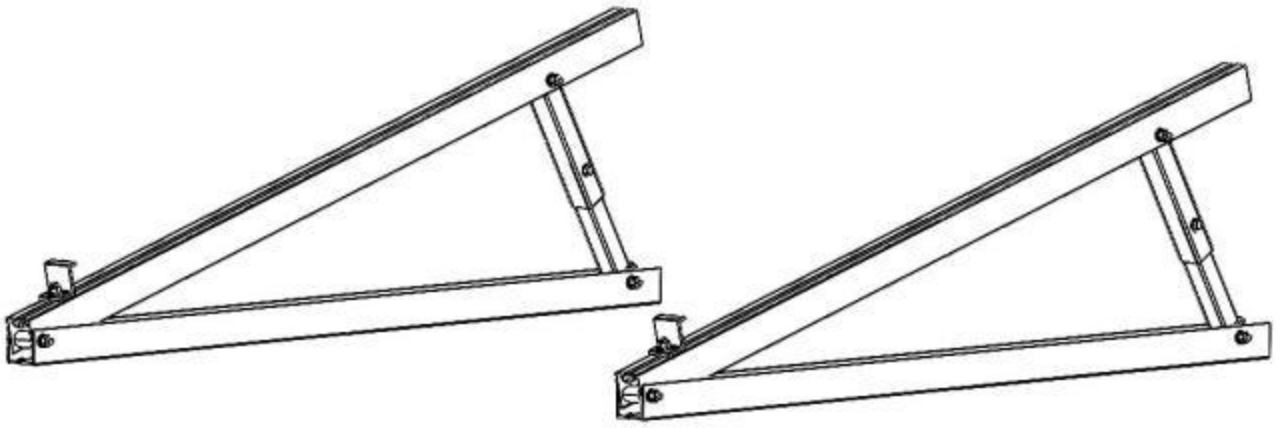

C. Put the solar panel on the mounted tripod and fix it at the four ends with side clamps

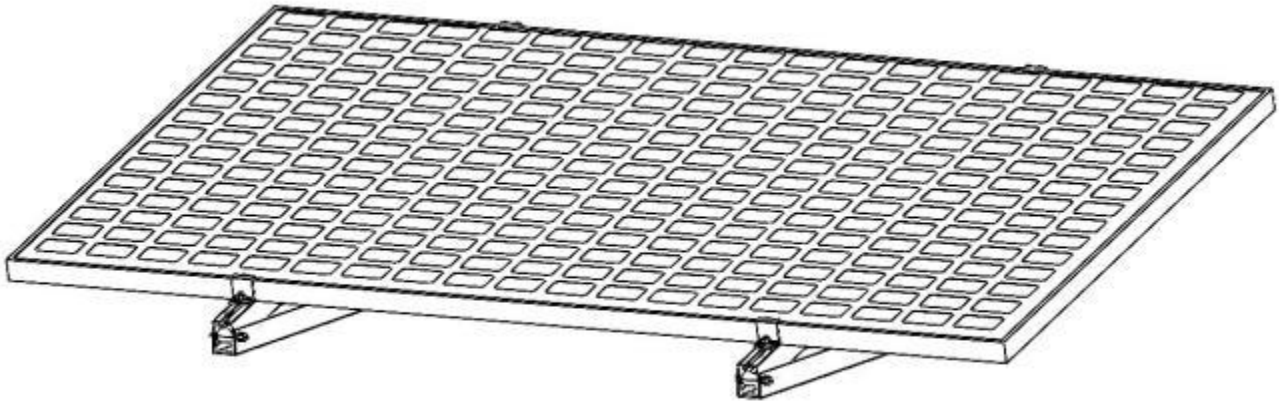

Step 4- Optional installation

The cross arm can increase the stability of the tripod and can install the inverter on it

a. Fix the cross arm to the bottom beam through the M8*50 bolt group

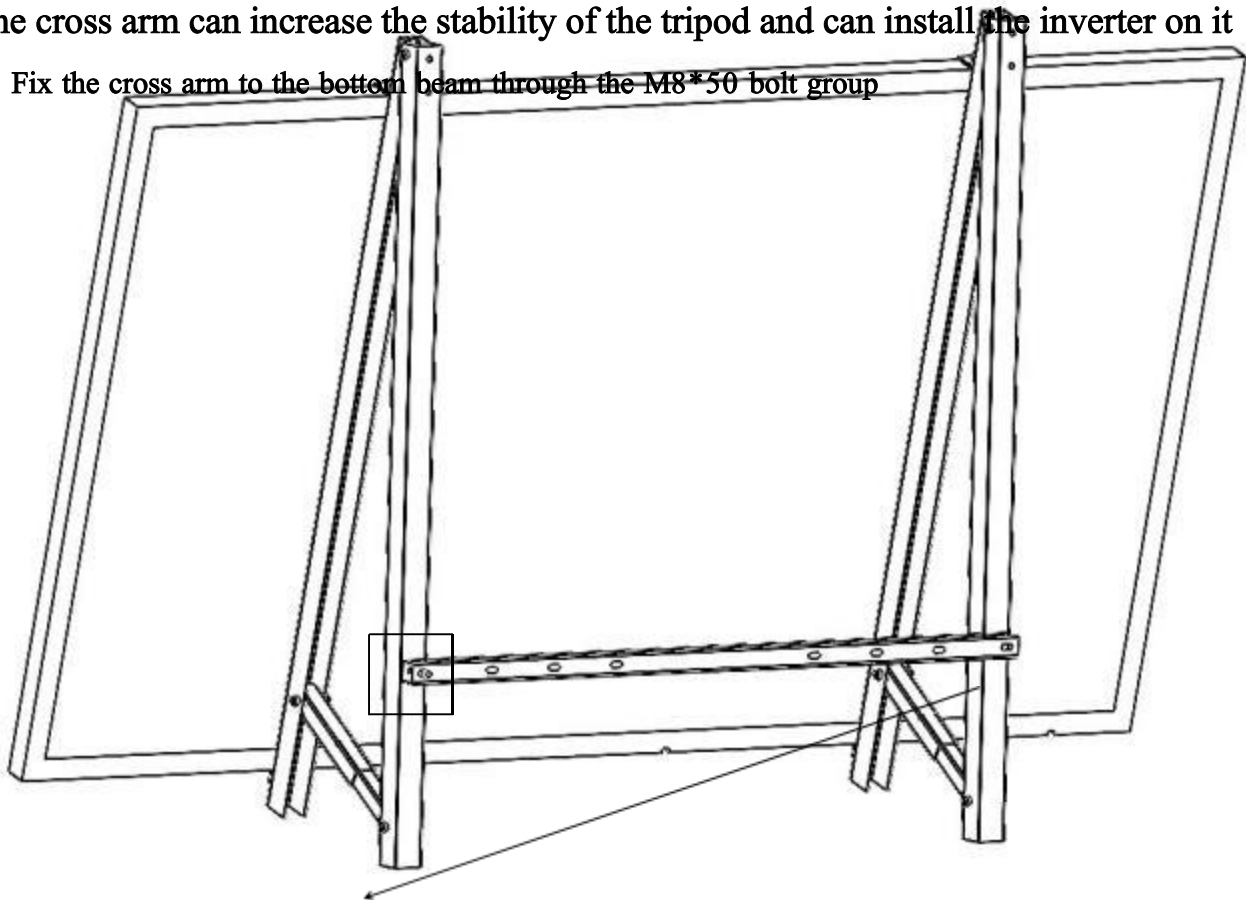



M8*55 bolt set



Stainless steel plates can be used to fasten cross arms and guardrails with bolt kits.

b. Stainless steel plate and cross arms clamp the guardrail through the bolt kit

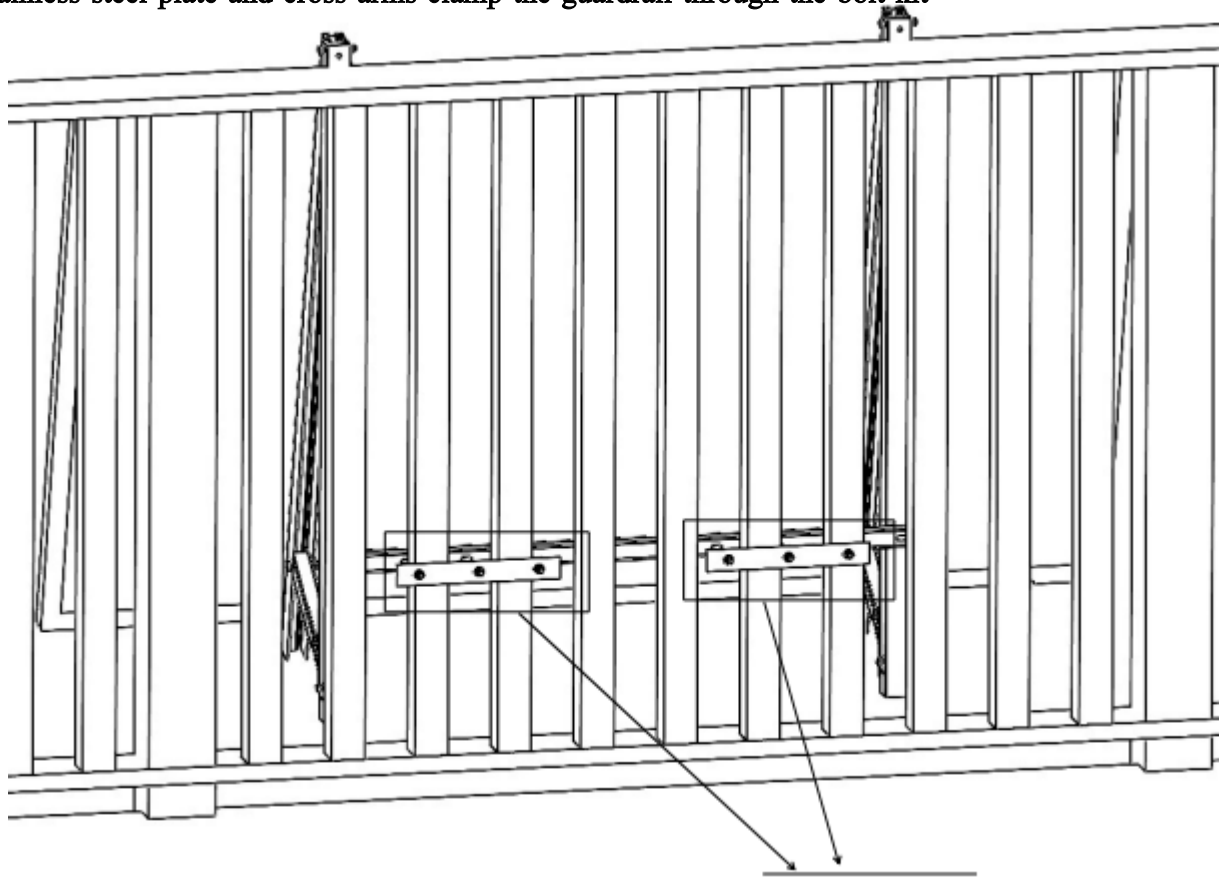

M8*95 bolt set

Tips:M1B-W1150 does not include a hook to fix the bracket to the guardrail, if necessary, it can be purchased separately according to the actual size of the guardrail.

SS304 (A2-70) Bolt torque recommendation table	
Bolt Specifications	Recommended torque value (N.M)
M8	8-10
M10	18-20
M12	50-55
M14	70-75
M16	90-95

Section 4-Final process of assembly

a. Wire rope installation details

③ Fix the solar panel at the other end



② Tighten the nut



① Through wire rope



It is protected by internal protective reinforcement, which is more secure

Tips for Bolt Installation

Precautions for engineering installation dimensions

- The specific dimensions of the engineering installation are subject to the engineering construction drawings. These installation instructions are for the purpose of explaining the installation method of the product only.

Precautions when installing stainless steel fasteners

- Because stainless steel has good ductility, it is essentially different from carbon steel; improper use will cause the bolt and nut to be unscrewed after being matched. That is, "locking" is commonly known as "biting to death". The prevention of lockup mainly includes the following aspects:

Reduce friction coefficient:

1. Ensure that the thread surface is clean (such as no sand, debris);
2. It is recommended to coat the surface with water wax or add lubricant (such as butter, 40# engine oil) during installation;

Correct operation method:

1. It must be screwed perpendicular to the axis of the thread, and must not be inclined;
2. During the tightening process, the force must be uniform, and the tightening torque cannot exceed the specified safe torque value;
3. Use a torque wrench or socket wrench as much as possible, and avoid using an adjustable wrench or an electric wrench; when using an electric wrench, try to reduce the speed as much as possible.
4. Avoid using at high temperature, do not rotate quickly when using, avoid the temperature rising rapidly and cause locking; (such as using an electric wrench, etc.)

Check after installation

It needs to check the condition of all the components and parts after finishing assemble of fixed mounting system:

- Checking if there are damage
- Checking if there are something forget to assemble
- ⚠ Checking if all the bolts locked tightly
- Checking if all the modules assembled accordance
- Cleaning project site after assembling.

Warning: It needs to check structure condition of mounting system before wiring.

- Before construction of Junction box and other electric equipments which will be installed in mounting system must be confirmed by technical people .

Daily maintenance

Maintenance instruction	Maintenance part
<ul style="list-style-type: none">➤ Maintenance of connected bolts● Checking every bolt junctions once a year , tightening if the junction is loosening	

